

PSA Design Development
RESIDENTIAL & COMMERCIAL
CUSTOM SERVICES
Patrick Saucedo, AIA
Project Manager
(817) 808-2664
Dallas, FTW/TEXAS
Patmanwil@gmail.com

TEXAS BOARD
ARCHITECTURAL
EXAMINERS
REGISTRATION #BR-2422

S.C. Owner:

"Food Plus"
Shopping Center Tenant, Retail bldg.
10819 Elam Road, Dallas, Texas

REVISION

ISSUE FOR REVIEW	DATE	REVISED PER COMMENTS
7-16-19		
11-1-19		
12-4-19		

DRAWN BY:	CHECKED BY:
ORIG. DATE:	REV. DATE:
JOB NO.:	SHEET NO.:
SCALE:	SP1

SITE DATA
ZONING : CR-D-1 REQUEST: SUP FOR ALCOHOL SALES
LOT AREA : 13,010 S.F.
AREA OF REQUEST : 2,250 S.F.
FAR = .17
REQUIRED PARKING = 12 PROVIDED PARKING = 12
EXISTING CONVENIENT STORE

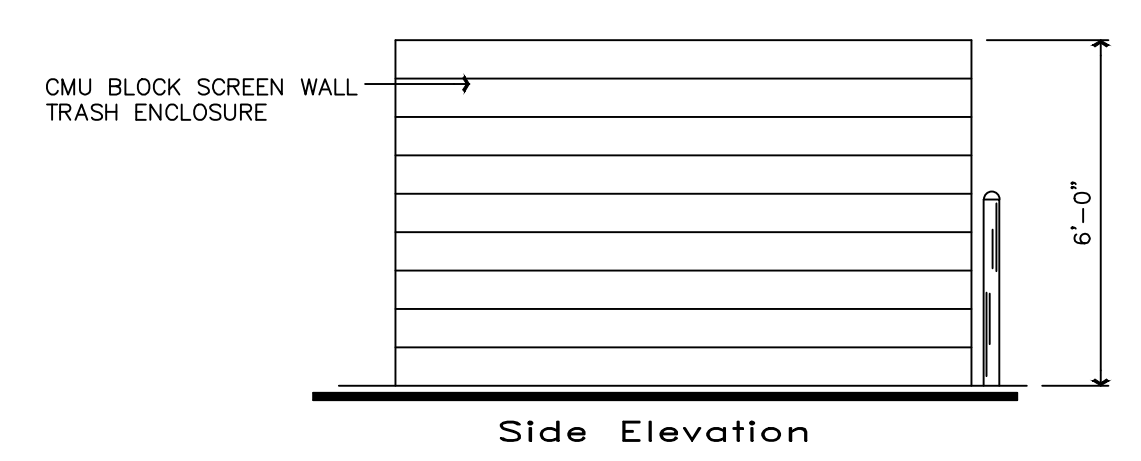
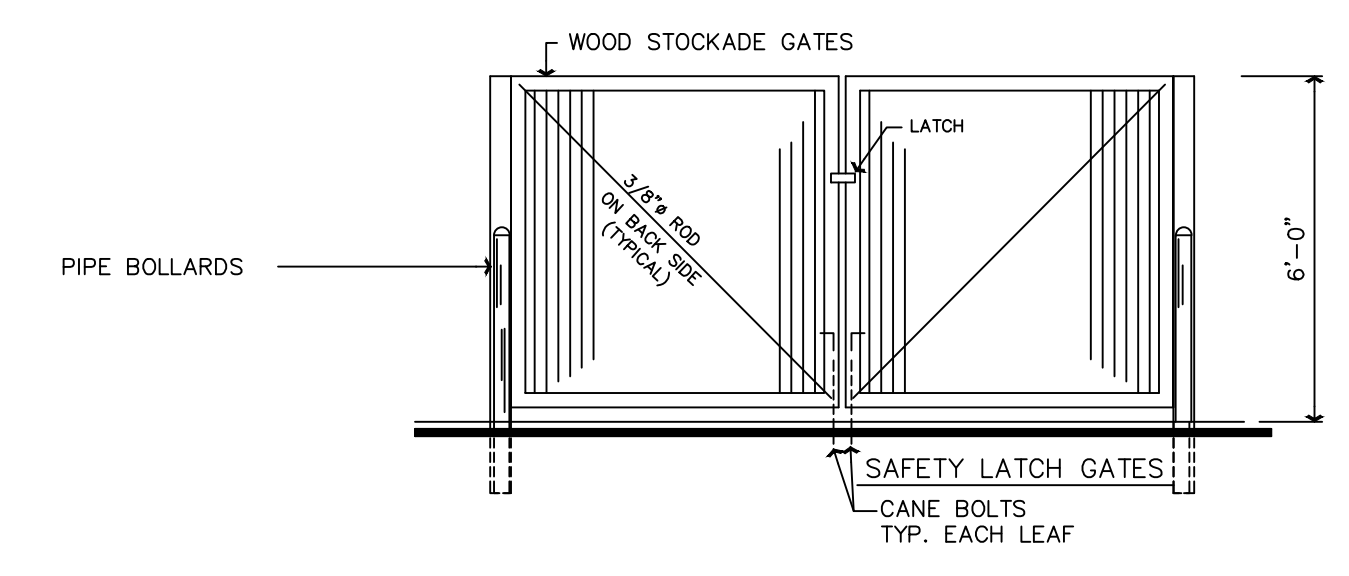
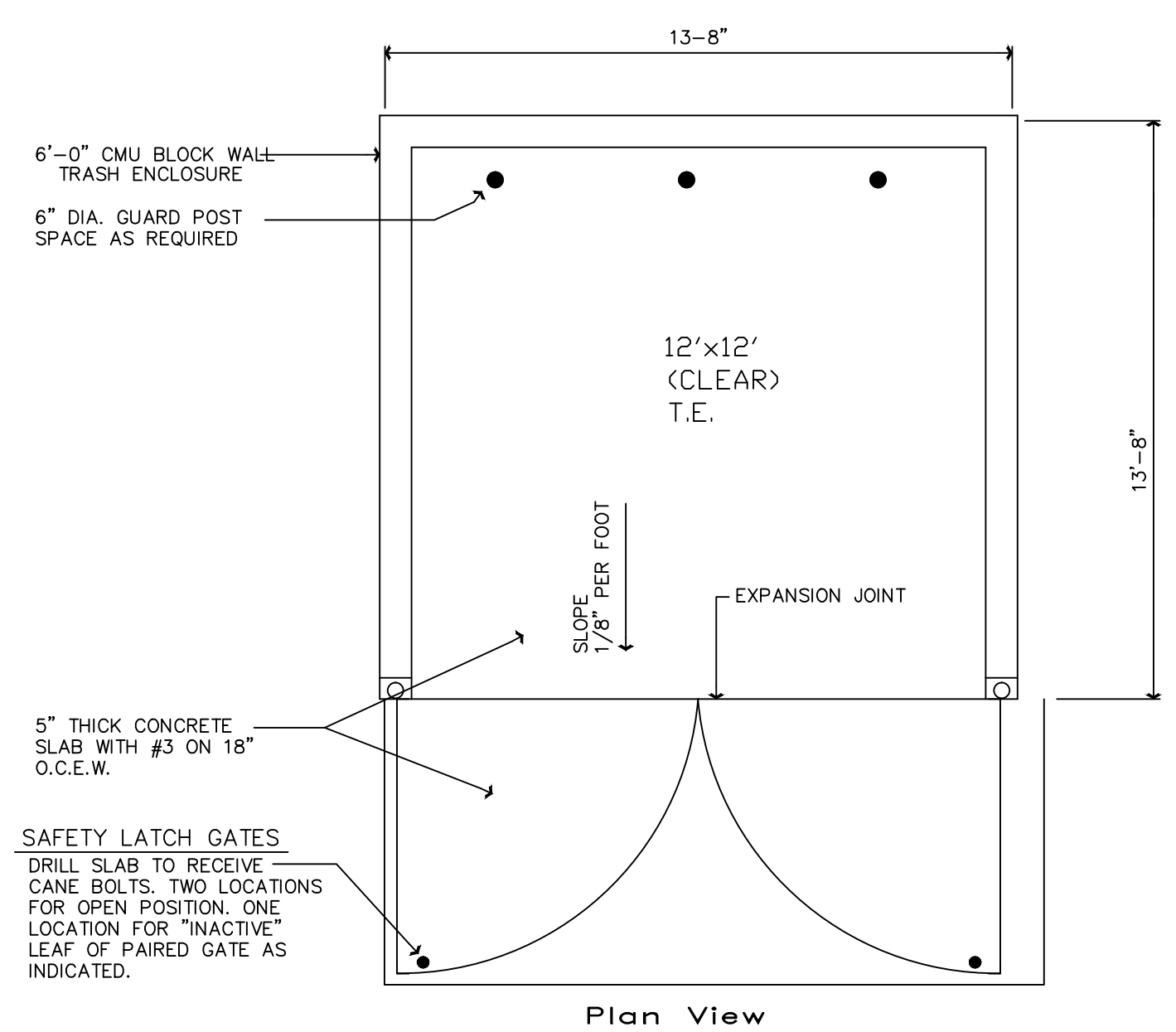

8 Detail - Trash Dumpster Enclosure
SP3 NO SCALE

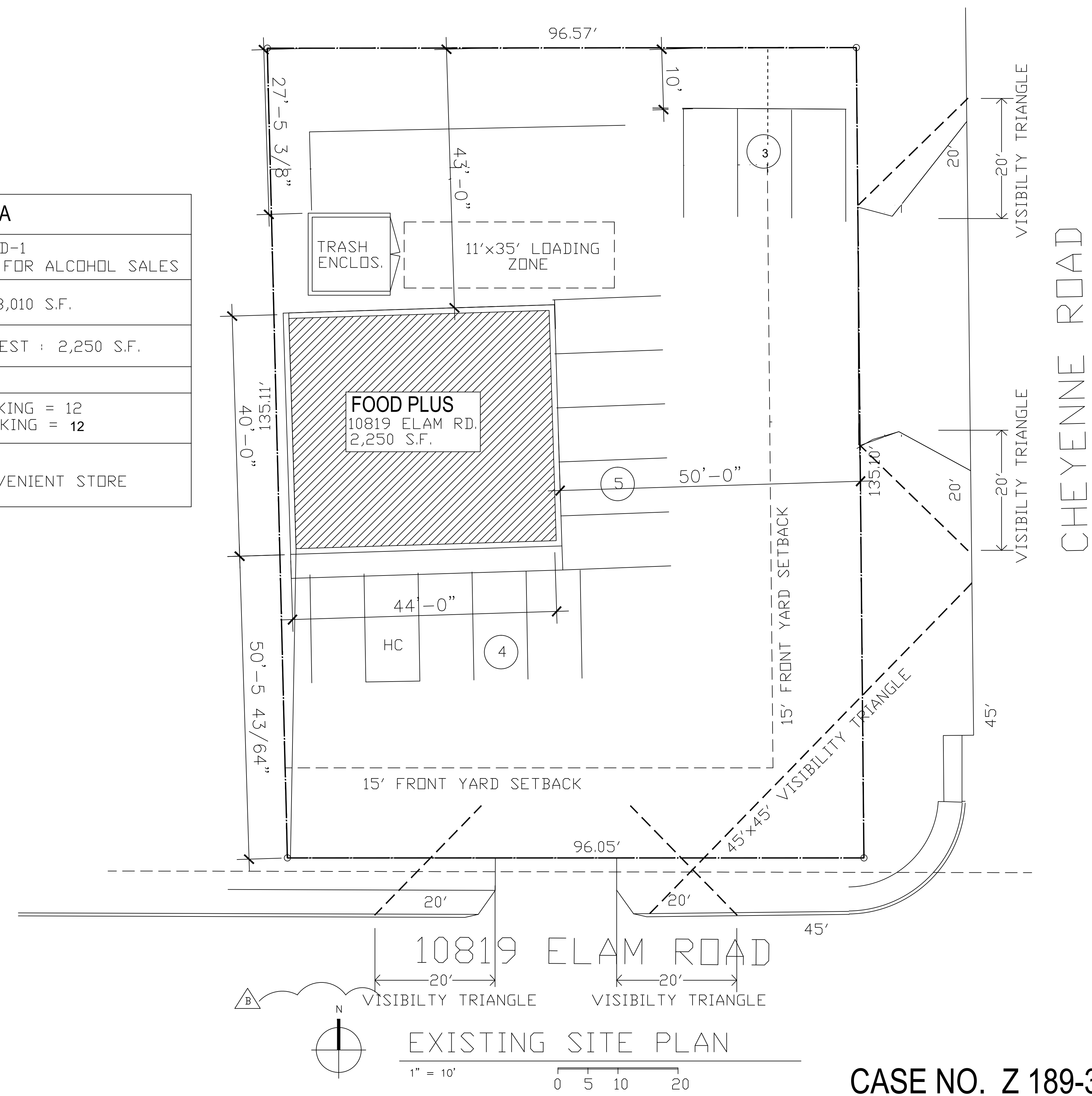

CASE NO. Z 189-362